

The premier source of tooling, parts, and accessories for bench top machinists.



HiTorque 7x16 Mini Lathe Users Guide

Model 5100 • Model 5200 Deluxe
from LittleMachineShop.com

© Copyright 2015 LittleMachineShop.com
All rights reserved.

Photos © Copyright 2015 PhotoBoost.com
All rights reserved.

Written by Chris Wood of LittleMachineShop.com

Revision 1, June 2015

LittleMachineShop.com
<http://www.littlemachineshop.com>
396 W. Washington Blvd. #500, Pasadena, CA 91103
(800) 981-9663 • Fax (626) 584-5844

Contents

Introduction	5
Specifications	5
Safety Considerations	6
General Safety.....	6
Lathe Safety	6
Electrical Safety.....	6
Machine Safety	7
Features.....	8
Front View	8
Rear View	9
Accessories	9
Cleaning.....	10
Assembly	10
Mounting Your Lathe	10
Operating Controls	11
Motor Controls.....	11
Power Feed Forward/Neutral/Reverse Lever.....	12
Power Feed Lever.....	12
Carriage Hand Wheel	12
Cross Slide Feed Handle.....	13
Compound Rest Feed Handle.....	13
Digital Position Readout (Model 5200 only)	13
Compound Rest Rotation.....	14
Tailstock Locking Lever	15
Tailstock Quill Hand Wheel	15
Tailstock Quill Locking Lever.....	15
Adjustments	15
Carriage	15
Cross Slide Gibs.....	16
Cross Slide Nut	17
Compound Rest Gibs.....	18
Apron Position	18
Tailstock Position	18
Half Nuts	19
Lead Screw Mounting.....	20
Drive Belt.....	20
Maintenance	21

Cleaning	21
Lubrication	21
Changing Chuck Jaws.....	23
Mounting Work in a 3-Jaw Chuck	24
Grinding Tool Bits.....	24
How to Grind Tool Bits	26
Grind the Front Relief	26
Grind the Left Side Relief.....	26
Grind the Top Rake	26
Round the Nose.....	27
Adjusting Tool Bit Height	27
Turning	27
Manual Turning	27
Turning with Power Feed	28
Facing	29
Turning Angles	30
Threading	30
Change Gears	31
Threading Dial	34
Tool Bit	35
Compound Angle	36
Setting the Cutting Tool	36
Threading Process.....	37
Common Accessories	38
Cut-Off Tool Holder.....	38
Quick Change Tool Post	38
Indexable Turning Tools.....	39
4-Jaw Chuck	40
Faceplate.....	40
Centers and Dogs.....	41
Steady Rest and Follower Rest	41
Parts Diagram	42
Parts List	43
Parts List	45
Wiring Diagram.....	46

Introduction

This user's guide covers care and operation of the LittleMachineShop.com HiTorque 7x16 Mini Lathe. Be sure to read and understand the safety guidelines presented in this book before using your HiTorque Mini Lathe.

The HiTorque 7x16 Mini Lathe is available in two models:

- Model 5100 is the standard version.
- Model 5200 is the deluxe version. It includes all the features of Model 5100 and adds:
 - Digital position readouts (DRO) on compound rest and cross slide
 - Metal hand wheels and chrome levers
 - Quick change tool post (QCTP) set with five tool holders

Chris' Tip: You can upgrade your Model 5100 lathe with the following kits available from LittleMachineShop.com:

- Part number 2222: Digital Position Readout, 2-Axis Mini Lathe
- Part number 3937: Knob and Hand Wheel Kit
- Part number 3112: Quick Change Tool Post Set, Tormach 0XA

Installation of all three kits creates a machine that is functionally identical to a Model 5200 deluxe lathe.

Specifications

Swing over bed	7.1" (180 mm)
Swing over saddle	4.3" (110 mm)
Between centers	16.1" (410 mm)
Spindle taper	Morse taper 3
Tailstock taper	Morse taper 2
Spindle bore	0.8" (20 mm)
Cross slide travel	2.6" (65 mm)
Compound rest travel	2.2" (55 mm)
Spindle speed	100-2500 RPM
Automatic feed rate	0.004" (0.1 mm)/ revolution
Range of threads	4-80 TPI (0.3-8 mm)
Power requirements	120 V 60 Hz 8 Amps
Spindle motor output	0.67 hp (500 Watts)

Safety Considerations

Always use common sense when using a power tool. Besides the general safety rules for any power tool, following also are specific considerations for the mini lathe.

General Safety

- Use common sense. Think through the results of your actions before you act.
- Understand the operation of the machine. Do not operate the machine if you do not know what is going to happen.
- Learn, don't experiment. Study, understand, and do things where you have a clear expectation of the outcome. Don't "see what will happen."
- You are responsible for your own actions. We can't be held responsible for your actions when you use the machine.

Lathe Safety

- Your mini lathe is just that, a *mini*, or small lathe. Don't attempt jobs that are beyond its capacity.
- Check the workpiece after you place it in the chuck or other work holding device. Be sure it is secure before turning on the lathe.
- Don't wear loose clothing or jewelry when operating the lathe.
- Stop the spindle and make sure the machine is in a safe condition before:
 - Opening or removing safety shields
 - Reaching into work area
 - Changing or adjusting tools
 - Changing or adjusting workpieces
 - Changing speed ranges
 - Clearing chips or coolant
- Inspect cutting tools for sharpness, chips, and cracks before each use. Replace dull, chipped, or cracked cutting tools immediately.
- Handle cutting tools with care. Cutting edges are very sharp and can cause lacerations.
- Do not use unbalanced workpieces or fixtures in the spindle
- Remove all tools (wrenches, chuck keys, locking pins, and so on) from the spindle immediately after using them.

Electrical Safety

- Plug the machine into a grounded, ground fault protected receptacle.

- Ensure that all components are properly grounded. The easiest way to ensure this is to plug your machines and devices into grounded outlets that you have tested.
- Use caution when using liquids and electricity. Ensure that coolants and lubricants are kept away from high voltage electrical components.
- Disconnect all components from the power receptacle before servicing.
- In the event of a power outage, turn off all components to ensure that the machine does not restart unexpectedly.

Machine Safety

- Keep bystanders, children, and visitors a safe distance away while operating any power tool.
- Read the manual. Know the operation of every control before you attempt any operation of the machine.
- Make sure that all guards are in place and functioning before operating the machine.
- Check for damage and abnormal wear before operating the machine.
- Always wear safety glasses (side shields are recommended) that are ANSI Z87.1-2003 compliant.
- Wear hearing protection (ear plugs or ear muffs) when operating loud machines.
- Wear appropriate clothing; no rings, gloves, neckties, jewelry, or loose-fitting garments. Bind long hair or wear a hat.
- Do not use compressed air for cleaning machines. A shop vacuum works well and is much safer.
- Don't operate machinery while under the influence of drugs or alcohol.
- Ensure that your machines are well lit. Ensure that your shop is well lit, and have additional task lighting where appropriate.
- Maintain a clean and uncluttered work area.
- Avoid pinch points.
- Never leave a running machine unattended.
- Do not force or overload machinery.
- Use appropriate cutting tools with appropriate feeds and speed.
- Cutting tools get hot during use and can cause burns if handled inappropriately.
- Do not attempt to use workpieces that are too large or too heavy for the machine.
- Maintain your machines. Ensure that it is well-adjusted and in a safe state.
- Clear chips with a brush or other tool, never with your hands or with compressed air.

- Make sure the machine is on a flat, level surface that is capable of supporting the weight of the machine plus fixtures, vise, and workpiece.
- Clamp work securely. Cutting forces are significant and can turn workpieces that are not secured into projectiles.
- Be aware that chips and dust from some materials (magnesium, for example) are flammable. Understand the materials you are using.

Features

Front View

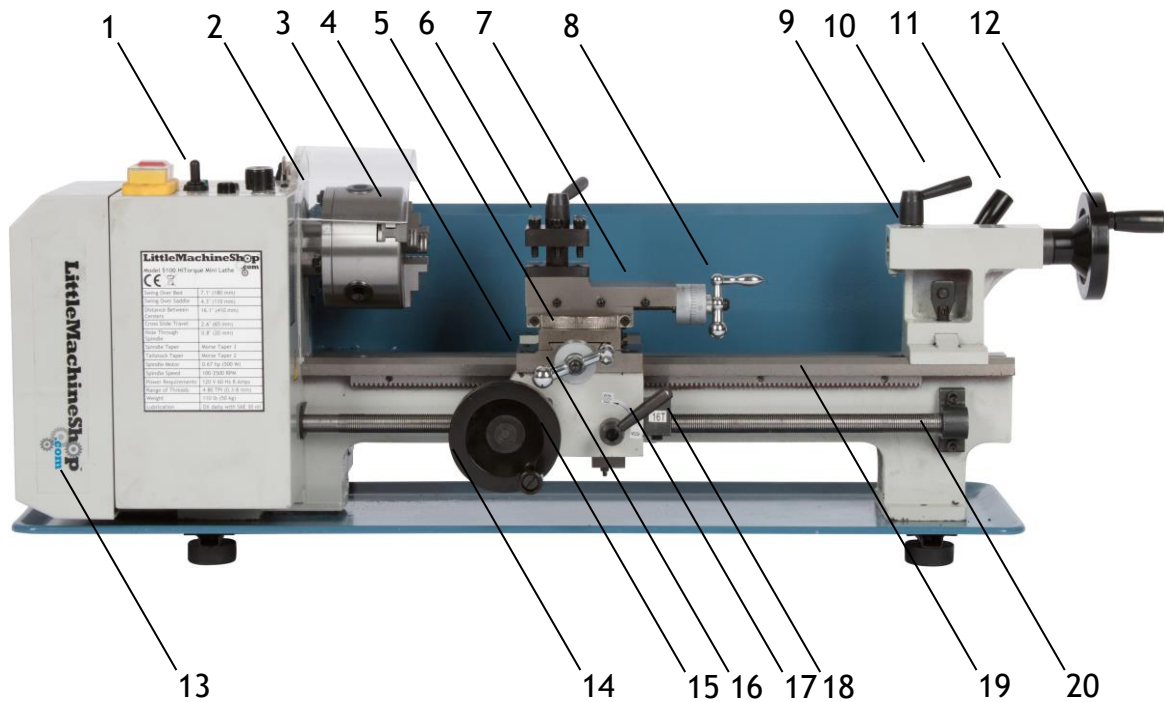

- | | |
|-----------------------------------|--------------------------------|
| 1. Motor controls | 11. Tailstock locking lever |
| 2. Headstock | 12. Tailstock quill hand wheel |
| 3. 3-jaw chuck | 13. Change gear cover |
| 4. Carriage | 14. Carriage hand wheel |
| 5. Cross slide | 15. Apron |
| 6. Tool post | 16. Cross slide feed handle |
| 7. Compound rest | 17. Power feed lever |
| 8. Compound rest feed handle | 18. Threading dial |
| 9. Tailstock quill | 19. Bed ways |
| 10. Tailstock quill locking lever | 20. Lead screw |

Rear View

Power feed forward/
neutral/reverse lever



Accessories



The following accessories come with the HiTorque Mini Lathe.

- Chuck key for the 3-jaw chuck
- Outside jaws for the 3-jaw chuck
- Change gears: 21, 30, 35, 40 (2), 45, 50, 55, 57, 60, and 65 teeth
- Hex wrenches: 3, 4, 5, and 6 mm
- Open end wrenches: 8 x 10 mm and 14 x 17 mm
- #2 Morse taper Dead center
- Oil can (plastic)

Cleaning

Your lathe will arrive coated with grease to protect it from corrosion during shipment. Follow this procedure to remove the grease:

1. Wipe most of the grease off with rags or paper towels.
2. Clean the surfaces with mineral spirits (paint thinner).
3. Coat the surfaces with oil.

See "[Lubrication](#)" on page 21 for specific recommendations for lubricants.

Assembly

There are two things to do to assemble your lathe.

1. Reverse the chrome crank handle on the cross slide.
2. Install the mounting feet and spreader bars on the lathe. Use the M6 socket head cap screws that are furnished. Instead of installing the mounting feet, you may wish to mount your lathe to a bench as described in the next section.



Mounting Your Lathe

The HiTorque Mini Lathe comes with rubber feet and spreader bars that attach to the same holes used to secure the lathe for shipping. If you want your lathe to be portable, simply install these spreader bars and feet.

You can also bolt your lathe to your workbench. The following diagram shows the holes required.

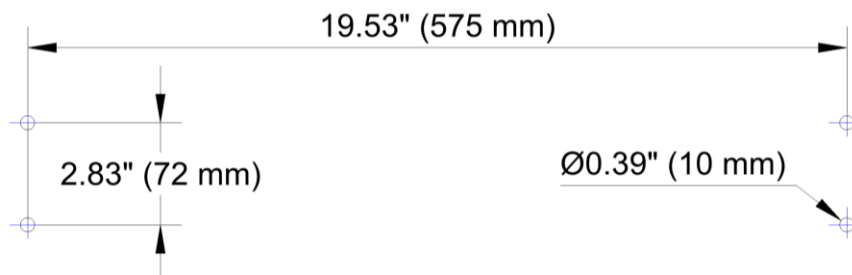

Mount the lathe to the workbench with M8 bolts. The bolts should be about 0.4" (10 mm) longer than the thickness of the workbench. Use fender washers on the underside of wooden benches to prevent the bolt heads from pulling through.

Operating Controls

There are several controls used to operate the lathe. Become familiar with them before you use the lathe.

Motor Controls

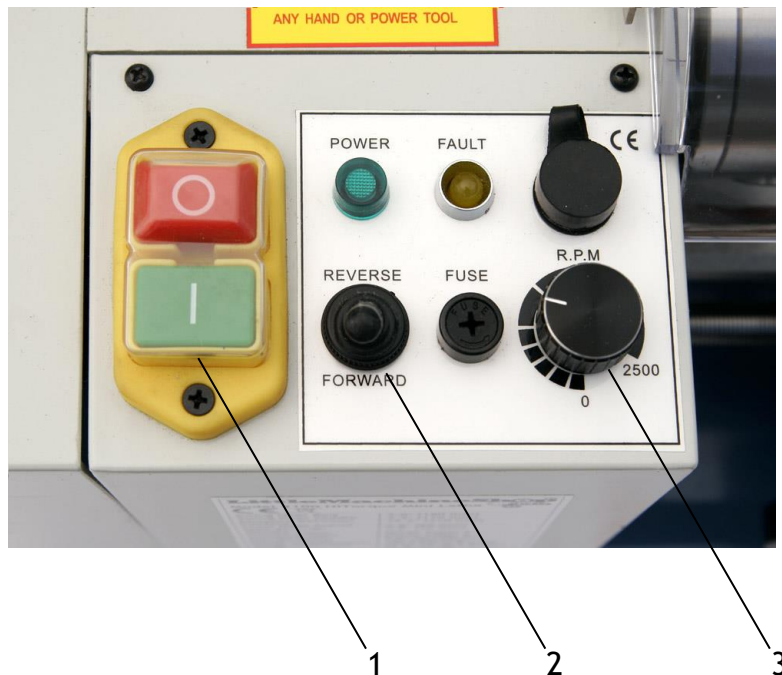

1. Power and emergency stop (E-stop) switch
2. Forward/off/reverse switch
3. Speed control

The red E-stop switch latches in the off position when you press the red button. To turn the switch on, press the green button.

The power switch interrupts the input power to the speed control circuit board.

The forward/off/reverse switch switches the polarity of the speed control circuit board output power between the speed control circuit board and the motor.

You control the motor speed by adjusting a potentiometer that provides the speed setting value to the speed control circuit board.

You can change the motor direction at any time and at any speed that safety allows. The motor will make a controlled stop or a controlled change of direction.

To power up the lathe:

1. Turn the speed control to the minimum speed position.
2. Place the forward/off/reverse switch in the off position.
3. Turn on the power switch by pressing the green button.

To start the lathe:

1. Ensure that the speed control is set to the minimum speed position.
2. Move the forward/off/reverse switch to the appropriate position.
3. Advance the speed control to the desired speed.

To stop the lathe:

1. Turn the speed control to the minimum speed position.
2. Move the forward/off/reverse switch to the off position.
3. If you want to power down the lathe, press the red switch to turn off the power.

Power Feed Forward/Neutral/Reverse Lever

The power feed forward/neutral/reverse lever controls the direction of rotation of the lead screw. When this lever is in the forward, or top, position the lead screw moves the carriage toward the headstock. When this lever is in the reverse, or bottom, position, the lead screw moves the carriage away from the headstock. In the center, or neutral, position the lead screw is disengaged and does not turn.

There is a strong spring in this lever. Pull out firmly on the end of the lever while moving it.

Power Feed Lever

The power feed lever locks the half nuts around the lead screw, which engages the power feed.

The power feed is engaged when this lever is down, and disengaged when this lever is up.

Carriage Hand Wheel

The carriage hand wheel moves the carriage toward or away from the headstock, depending on which way it is turned.

Use this hand wheel to position the carriage. Because this hand wheel moves the carriage quickly it is not easy to use this hand wheel to move the carriage while you are turning.

You cannot turn this hand wheel when the automatic feed is engaged.

Cross Slide Feed Handle

The cross slide feed handle moves the cross slide across the ways. Use this handle to advance the tool into the work and for facing cuts.

The dial on this handle indicates the relative position of the cross slide. The graduated dial can be repositioned for convenience.

There are 40 divisions on the dial. Each turn of the handle advances the cross slide 1 mm or approximately 0.040". The distance is actually 0.03937", an error of a little less than 2%.

Compound Rest Feed Handle

The compound rest feed handle advances or retracts the compound rest. Use this handle to advance the tool into the work.

The dial on this handle indicates the relative position of the compound rest. The graduated dial can be repositioned for convenience.

There are 40 divisions on the dial. Each turn of the handle advances the compound rest 1 mm or approximately 0.040". The distance is actually 0.03937", an error of a little less than 2%.

Digital Position Readout (Model 5200 only)

The HiTorque 7×16 Deluxe Mini Lathe has digital readouts on the compound rest and cross slide.

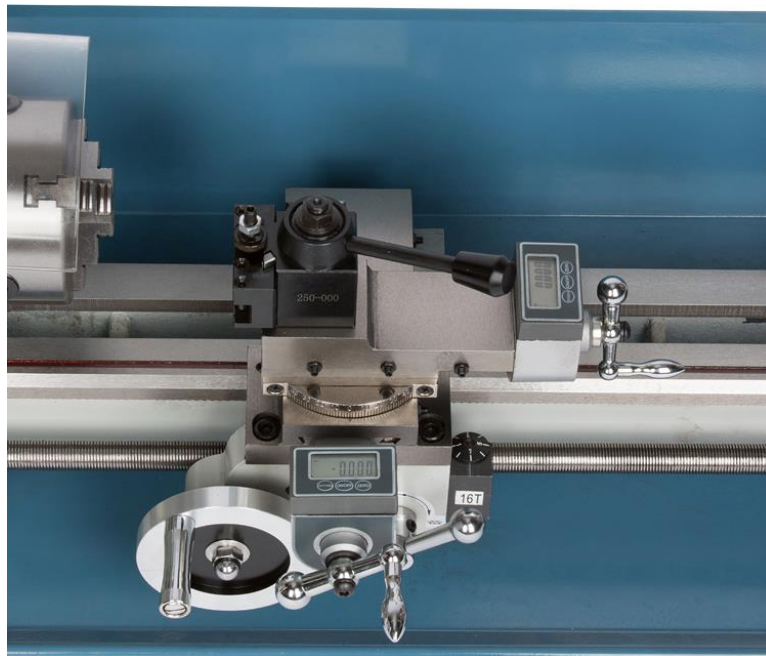

Initialization

When shipped, the digital readouts have a slip of plastic between the battery and the battery terminal. Pull out this plastic to provide power to the readout. Discard the plastic.

To use the digital readouts:

The readouts are easy to use. There are three buttons: ON/OFF, ZERO, and in/mm.



Button	Function
ON/OFF	Turns the display on and off. Turn the display off when you are not using it to extend battery life.
in/mm	Switches the display between inches and millimeters.
ZERO	Sets the display to zero at the current position.

Chris' Tip: These digital readouts do not account for backlash in the feed screw. Always take your readings when you are turning the screw in the same direction. This is not a problem on a lathe, because a single cut will only be made in one direction—in for turning, and out for boring.

To replace the battery:

Each DRO uses a single AG10 watch battery.

1. Remove the two small Phillips head screws from the side of display unit and remove the small plastic plug.
2. Pull the ribbon to remove the battery.
3. Replace the battery, ensuring that the ribbon is behind it.
4. Replace the plastic plug and screws.

Compound Rest Rotation

The compound rest rotates on the cross slide and you can position it at any angle.

Position the compound rest so it moves parallel to the ways to make precise facing cuts.

Position the compound rest at 29.5 degrees for cutting standard threads.

To change the angle of the compound rest:

1. Using the compound rest feed handle, retract the compound rest until the locking socket head cap screws are exposed.

2. Loosen the two socket head cap screws.
3. Turn the compound rest to the desired angle.
4. Tighten the two socket head cap screws.

Chris' Tip: Use a protractor between the compound rest and the cross slide. Don't depend on the die cast or plastic markings on the side of the compound rest.

Tailstock Locking Lever

The tailstock is locked into position on the ways by the tailstock locking lever on the back of the tailstock. Raise the lever towards the vertical to tighten the tailstock lock.

Tailstock Quill Hand Wheel

The tailstock quill hand wheel moves the tailstock quill in and out. Most mini lathes have rather poor graduations on the top of the quill that show how far it is extended.

Retract the tailstock quill all the way to remove tools from the taper in the tailstock quill.

Tailstock Quill Locking Lever

The tailstock quill locking lever keeps the tailstock quill from moving. Use the tailstock quill locking lever to lock the tailstock quill in position when you are turning between centers. Turn the lever clockwise to lock the tailstock quill, and counterclockwise to unlock the tailstock quill.

Adjustments

Keeping your lathe in adjustment is an ongoing process. You should check all the following adjustments when you set up your lathe and then periodically as you use your lathe. Looseness in the carriage retaining plates or the gibs can cause chatter when you are using the lathe. If you experience chatter, check all these adjustments.

Carriage

The carriage is held on the ways by two adjustable retaining plates that are bolted to the bottom of the carriage.

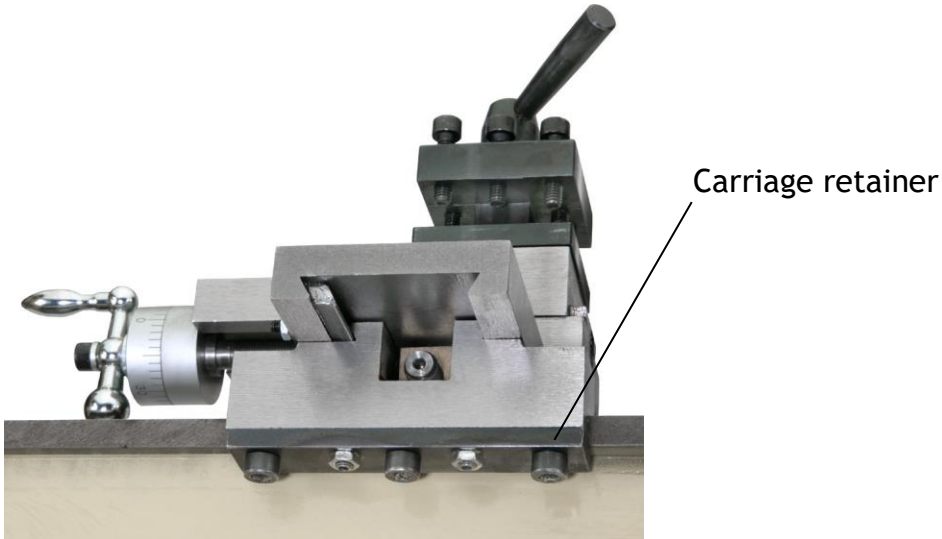

There are several fasteners in the carriage retainers. The socket head cap screws are used to adjust the position of the retainers. The setscrews and lock nuts lock the adjustments in place.

To adjust the carriage retainers:

1. Remove the right lead screw mounting bracket.
2. Disconnect the apron by removing the two socket head cap screws through the front of the carriage.
3. Slide the apron to the right and off the lead screw.
4. Loosen all the fasteners on both retainers.
5. Snug the socket head cap screws so the carriage can move, but without play.
6. Snug the setscrews. Do not over tighten or you might break the retainers.
7. While holding the setscrews from turning, tighten the lock nuts.
8. Replace the apron.
9. Replace the right lead screw mounting bracket.

Cross Slide Gibs

A gib is a strip of metal placed between the bearing surface of two machine parts to ensure a precision fit and provide adjustment for wear. The mini lathe has gibs in several places, including the cross slide.



To adjust the cross slide gibs:

1. Loosen the three lock nuts on the side of the cross slide.
2. Slightly loosen all three setscrews on the side of the cross slide.
3. Snug each setscrew equally. This will lock the cross slide in position.
4. Loosen each setscrew 1/8 turn to allow the cross slide to move.
5. While holding the setscrews from turning, tighten the lock nuts.
6. Test by turning the handle. Loosen or tighten all the setscrews the same amount until the cross slide moves freely, but without play in the dovetail.

Cross Slide Nut

The cross slide nut is adjustable to remove free play from the cross slide feed handle.

The three screws in the top of the cross slide adjust the cross slide nut.

The two outer screws tip the nut off horizontal to reduce the endplay in the threads. The center screw locks the adjustment in place.

To adjust the cross slide nut:

1. Loosen all three screws.
2. Tighten the outside setscrews until you just start to feel resistance turning the set screw.
3. Loosen the near set screw and tightened the center screw until you just start to feel resistance turning the cap crew. At this point the bottom threads of the nut should be touching the lead screw at the far end, and the top threads of the nut should be touching the lead screw at the near end.
4. Tighten the front set screw.
5. Check the adjustment.
 - If the feed screw is too hard to turn, loosen the front set screw a little and then tighten the center cap screw.
 - If the feed screw is too easy to turn and you have excessive backlash, loosen the center cap screw a little and then tighten the front set screw.

Compound Rest Gibs

The compound rest also incorporates a gib for adjustment.

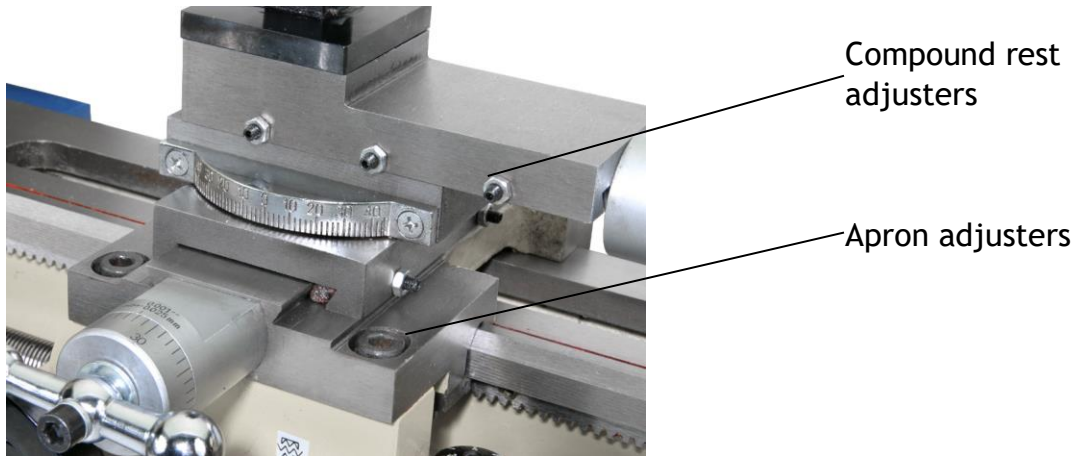

To adjust the compound rest gibs:

1. Loosen the three lock nuts on the side of the compound rest.
2. Slightly loosen all three setscrews on the side of the compound rest.
3. Snug each setscrew equally. This will lock the compound rest in position.
4. Loosen each setscrew 1/8 turn to allow the compound rest to move.
5. While holding the setscrews from turning, tighten the lock nuts.
6. Test by turning the handle. Loosen or tighten all the setscrews the same amount until the compound rest moves freely, but without play in the dovetail.

Apron Position

The apron is adjustable to center the half nuts horizontally on the lead screw.

To adjust the apron position:

1. Loosen the two socket head cap screws that secure the apron to the carriage. They are at the front edge of the carriage.
2. Engage the half nuts on the lead screw.
3. Tighten the two socket head cap screws.

Tailstock Position

The tailstock is adjustable from front to rear so you can align it with the spindle.

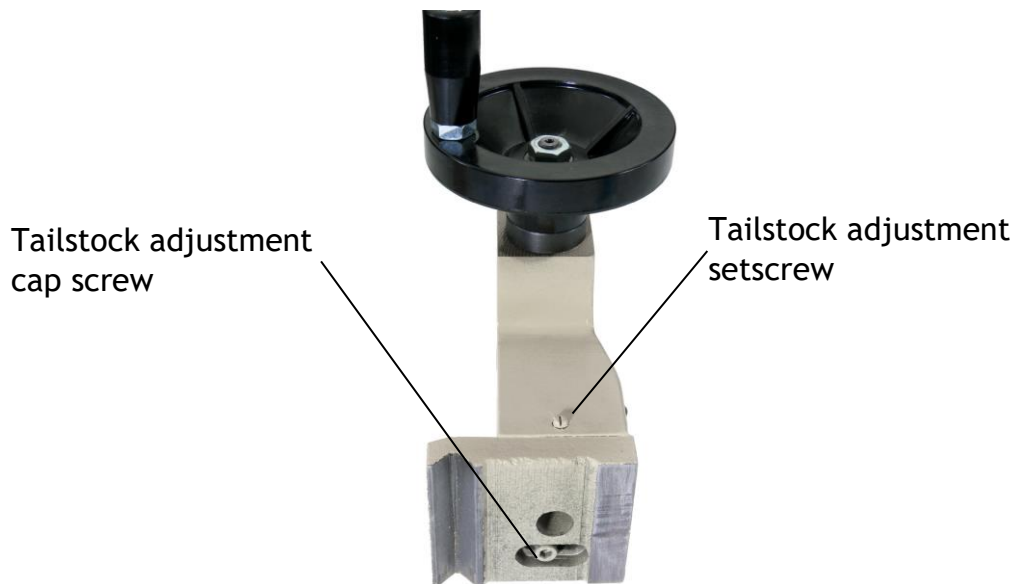

To adjust the tailstock position:

1. Remove the 3-jaw chuck from the lathe spindle.
2. Put a 3 Morse taper dead center in the spindle.
3. Remove the tailstock from the lathe.
4. Loosen the tailstock adjustment cap screw.
5. Place the tailstock back on the ways.
6. Put a 2 Morse taper dead center in the tailstock quill.
7. Move the tailstock toward the spindle until the two centers almost touch.
8. Loosen the tailstock adjustment setscrews.
9. Move the upper part of the tailstock casting until the centers are aligned.
10. Place a steel rule between the two centers. The length of the rule should be horizontal and the width vertical. Bring the centers together to hold the rule in place.
11. Adjust the upper part of the tailstock casting until the steel rule is perpendicular to the axis of the lathe. If the near end of the rule angles toward the headstock, move the tailstock back.
12. When the tailstock is in the correct position, tighten the tailstock adjustment setscrews.
13. Gently remove the tailstock from the lathe and tighten the tailstock adjustment cap screw.
14. Replace the tailstock on the ways and check the adjustment.

Half Nuts

There are two adjustments for the half nuts. The half nut gibs take the play out of the half nuts. The half nut closing limit stops the half nuts from closing too tightly on the lead screw.

To adjust the half nut gibs:

- Tighten the three setscrews in the back edge of the apron to remove play from the half nuts.

To adjust the half nut limit:

1. Loosen the lock nut on the bottom of the half nuts.
2. Adjust the setscrew until the half nuts close without binding on the lead screw.
3. While holding the setscrew from turning, tighten the lock nut.

Lead Screw Mounting

The brackets that mount the lead screw can move slightly to ensure that the lead screw does not bind in the half nuts.

To adjust the right lead screw mounting bracket:

1. Remove the tailstock by sliding it off the end of the ways.
2. Loosen the two mounting socket head cap screws on the right bracket.
3. Move the carriage as far to the right as possible.
4. Engage the half nuts on the lead screw.
5. Tighten the bracket mounting socket head cap screws.
6. Replace the tailstock.

To adjust the left lead screw mounting bracket:

1. Remove the change gear cover.
2. Loosen the locking nut on the change gear adjuster.
3. Loosen the two mounting socket head cap screws on the left lead screw bracket.
4. Move the carriage as far to the left as possible.
5. Engage the half nuts on the lead screw.
6. Tighten the bracket mounting socket head cap screws.
7. Tighten the locking nut on the change gear adjuster.
8. Replace the change gear cover.

Drive Belt

The drive belt is a timing belt and should rarely need adjustment.

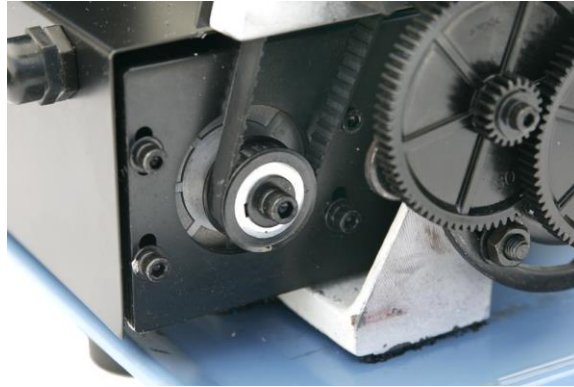

To adjust the drive belt:

1. Unplug the power cord.
2. Remove the change gear cover.
3. Loosen the four motor mounting socket head cap screws.
4. While you push down on the motor pulley with your left thumb, tighten one socket head cap screw on each side of the motor.
5. Tighten the other two socket head cap screw.
6. Replace the change gear cover.

Maintenance

Maintenance of the mini lathe is simple, but important. Regular maintenance will keep your mini lathe working like new for many years.

Cleaning

The maintenance you perform most often is cleaning. Keeping swarf (chips, shavings, and debris) off of wearing surfaces is the most important thing you can do to prolong the life of your mini lathe.

- Use a 1" paintbrush to remove swarf from the ways as you work.
- Clean the lead screw before each use.
- Clean swarf from the lathe, from top down after each use.

Lubrication

We recommend the use of two lubricants on your lathe.

- Where oil is required, we recommend Mobil 1 synthetic motor oil. Mobil 1 far exceeds the lubrication needs of the mini lathe, and maintains a good surface film between applications.

Chris' Tip: Don't worry about the viscosity. At room temperature, 5W-20 and 10W-30 are about the same.
--

- Where grease is required, we recommend Lubriplate 630-AA lithium (white) grease. Lithium grease is a plastic-friendly grease that is easy to find and easy to use.

Chris' Tip: You might have trouble finding Lubriplate 630-AA grease. Don't worry about the brand name. Get white lithium grease. Every auto parts store and most hardware stores will have it.

The following points on your lathe require lubrication.

Location	Lubricant	Frequency	Notes
Lathe ways	Oil	Daily	Apply oil to both the front and back ways on both sides of the carriage. Move the carriage back and forth to spread the oil.
Lead screw threads	Oil	Daily	Clean swarf (chips, shavings, and debris) daily.
Compound rest dovetail	Oil	Daily	Advance the compound rest to the extent of its normal travel. Apply oil to the end of the gib and the ends of the dovetails. Retract the compound rest.
Cross slide dovetail	Oil	Daily	Advance the cross slide to the extent of its travel. Apply oil to the end of the gib and the ends of the dovetails. Retract the cross slide.
Lead screw bushings	Oil	Weekly	There is an oil fitting on the top of each one. Remove the change gear cover to lubricate the left bushing.
Other machined surfaces	Oil	Weekly	Oil lubricates and prevents corrosion.
Chuck	Oil	Monthly	Disassemble, clean and lubricate. Wrap with a paper towel, secure with an elastic band, and run lathe to sling out excess oil.
Cross slide feed screw	Grease	Yearly	
Compound rest feed screw	Grease	Yearly	

Location	Lubricant	Frequency	Notes
Lead screw drive gears and bushings	Grease	Yearly	Also lube change gears as you use them.
Carriage hand wheel drive gears	Grease	Yearly	
Tailstock quill and screw	Grease	Yearly	

The spindle and countershaft bearings are deep groove ball bearings that are shielded and do not require additional lubrication.

Changing Chuck Jaws

3-jaw lathe chucks come with two sets of jaws.

The “normal” set is called the inside jaws, because the stepped side is designed to fit inside of hollow workpieces and hold by an outward force. In many cases, however, these jaws are used to clamp on the outside of smaller objects using the long straight side.



The second set of jaws is called the outside jaws because the stepped side of these jaws is designed to clamp on the outside of larger objects.



Because of the construction of a 3-jaw chuck, each of the three jaws in a set is different. You will find a number in the groove in the side of each jaw that identifies its position in the set.

To remove a set of chuck jaws:

1. Place a piece of wood on the ways to protect them in case you drop something.
2. Place your right hand around the chuck to prevent the jaws from falling out.
3. With your left hand, turn the lathe chuck key counter clockwise to open the jaws.
4. The jaws will come loose from the chuck, one at a time, when about half the length is exposed beyond the diameter of the chuck.

To install a set of chuck jaws:

1. Place the three jaws in numeric order on the bench.
2. Slide jaw number 1 into the slot in the chuck that has the serial number stamped in it.
3. Press the jaw into the slot with one hand, and with the other hand, turn the chuck key to open the chuck.
4. You will feel the jaw move out in the slot as you turn. Stop turning right after the jaw clicks inward in the slot.
5. Turn the chuck key to close the chuck about $\frac{1}{4}$ turn to engage jaw 1.
6. Slide jaw 2 into the next slot counterclockwise from jaw 1 when you are looking toward the headstock.
7. Slide jaw 3 into the open slot.
8. While pressing jaws 2 and 3 into the slots, turn the chuck key to close the chuck.

Mounting Work in a 3-Jaw Chuck

Three jaw lathe chucks are good for most lathe operations. All three jaws move together as you turn the chuck key. But, because of the way they are made, 3-jaw chucks have limited accuracy. They will center work to within about 0.003" runout. If you need better concentricity, use an independent 4-jaw chuck or a collet.

If you chuck a workpiece, create a part, and then part it off, the lack of concentricity will not cause a problem. The only time it is a problem is when you try to re-chuck a workpiece.

Place your workpiece between the jaws of the lathe chuck and turn the chuck key clockwise to close the jaws. Tighten firmly. To get the jaws as tight as possible, tighten all three locations with the chuck key.

Grinding Tool Bits

When you purchase a new lathe tool bit, it might have an angle on the end, but it is not properly sharpened for turning. Grinding lathe tool bits is a bit of an art. It takes some practice to get good at it.

You need to create a cutting edge that is sharp, extends out so that the cutting edge and not the side of the tool contacts the work, but that still has enough support to maintain sufficient strength to cut metal.

Before diving in, there are some terms you need to understand. The illustration below shows these terms.

First, notice that there are two cutting edges on the tool bit. There is a cutting edge on the end of the tool bit called the front cutting edge. There is also a cutting edge on the side of the tool. Between these cutting edges is a rounded section of cutting edge called the nose.

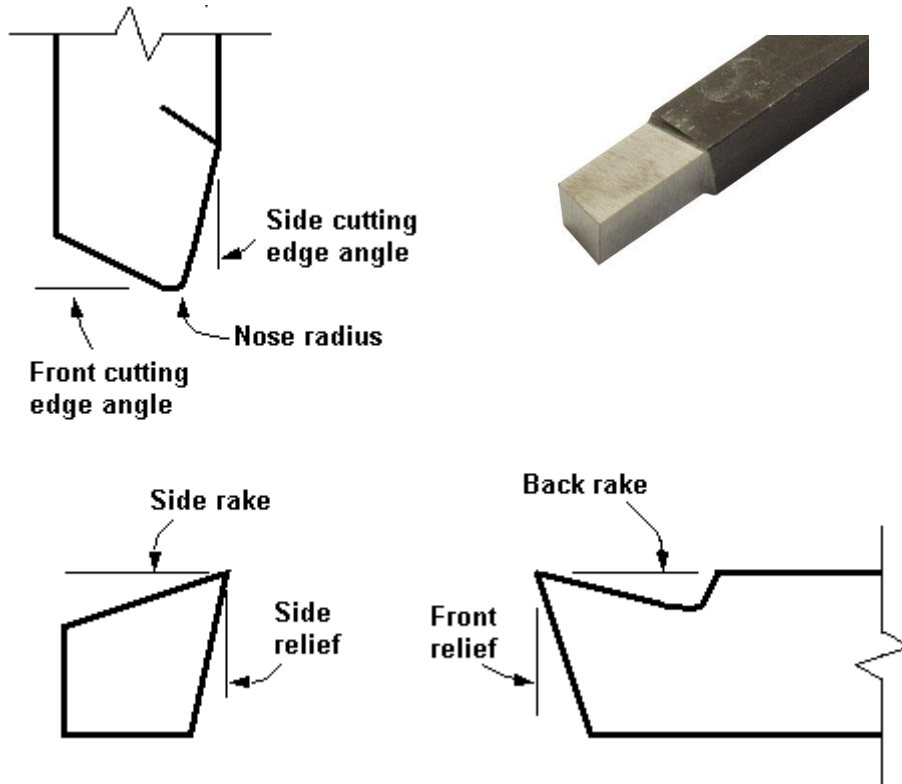

Side cutting edge	The side cutting edge does most of the cutting. As the tool bit moves along the workpiece the side cutting edge removes most of the material.
Front cutting edge	The front cutting edge cuts when the tool is advanced into the work.
Nose	The nose is a critical part of the cutting edge, because it produces the surface finish of the workpiece.
Side rake	The side rake produces the side cutting edge that cuts into the workpiece.

Side relief	Side relief provides clearance for the side cutting edge. Without side relief, the side of the tool bit would hit the workpiece and not allow the cutting edge to penetrate the workpiece.
Back rake	The back rake produces the front cutting edge that cuts into the workpiece.
Front relief	Front relief provides clearance for the front cutting edge. Without front relief, the front of the tool bit would hit the workpiece and not allow the cutting edge to penetrate the workpiece.

How to Grind Tool Bits

Use a bench grinder to sharpen your tool bits. Even an inexpensive bench grinder can do a good job grinding lathe tool bits. In some cases, you might want to purchase a higher quality fine grit wheel.

Keep a small cup of water near your grinder. Grinding generates heat, which can cause two problems. The tool bit will become too hot to hold. Overheating can also affect the heat treatment of the tool bit, leaving the cutting edge soft.

Use a protractor to measure the angles. They are not super-critical, but you should try to stay within one degree of the recommendations.

Grind the Front Relief

The first step in creating a tool bit is to grind the front relief. For most work, a relief angle of 10° works well.

While you are grinding the front relief, you are also creating the front cutting edge angle. Make this angle about 10° also, so that the corner formed by the front cutting edge and the side cutting edge is less than 90°.

Grind the Left Side Relief

Form the left side relief next. Again, create about a 10° angle. You don't need to form a side cutting angle. The side cutting edge can be parallel to the side of the tool blank.

Grind the Top Rake

The top of the tool bit is ground at an angle that combines the back rake and the side rake. The side rake is most important, because the side cutting edge does most of the work. For cutting steel and aluminum, the side rake should be about 12° and the back rake should be about 8°. For cutting brass, the rake angles should be much less, or even 0°.

Round the Nose

A small nose radius allows you to turn into tight corners. A large nose radius produces better surface finishes. Create a nose radius that is appropriate for the tool bit you are creating.

Adjusting Tool Bit Height

The cutting edge of the tool bit should almost always be set to the center height of the lathe spindle.



There are several methods for checking the height of the tool bit. Perhaps the simplest way is to place a thin strip of metal, such as a steel rule or feeler gage, between the workpiece and the point of the tool bit. If the height is correct, the strip of metal will be held vertical. If the top is leaning toward you, the tool bit is too low. If the top is leaning away from you, the tool bit is too high.

Using the standard tool post, you adjust the tool bit height using shims under the tool bit. You can get an economical set of shims, about the right size, at any auto parts store. Purchase a set of feeler gages and remove the pivot pin. The easy way to adjust the tool bit height is to get a quick change tool post. (Model 5200 includes a quick change tool post set.) Virtually all quick change tool posts incorporate a mechanism for easily adjusting the tool bit height.

Turning

The most common use of a lathe is turning down the diameter of a workpiece.

Manual Turning

Follow these steps to turn the outside diameter of a workpiece.

To turn manually:

1. Put a tool bit in the tool holder and adjust the cutting edge to center height.
2. Angle the tool so that the front cutting edge forms an acute angle with the axis of the workpiece, as shown in the illustration below.

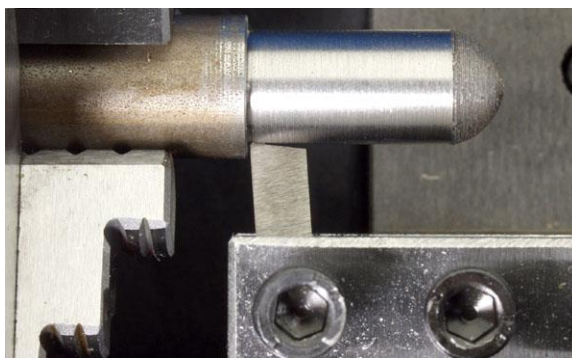

3. Move the carriage so that the tool bit is near the right end of the workpiece.
4. Turn the lathe on. Adjust the speed to an appropriate speed for the material and diameter you are working on. The LittleMachineShop.com Web site has a calculator to help you determine appropriate cutting speeds at <http://littlemachineshop.com/Reference/CuttingSpeeds.php>.
5. Using the cross slide feed handle, slowly advance the tool bit into the work until it just touches the surface of the workpiece.
6. Move the carriage to the right so that the tool bit is past the end of the workpiece.
7. Using the cross slide feed handle, advance the tool bit about 0.010".
8. Using the carriage hand wheel, move the carriage slowly to the left. As the tool bit meets the workpiece, it starts cutting.

Turning with Power Feed

The mini lathe incorporates a power carriage feed that can move the carriage either direction. This same power feed is used for turning and threading.

For turning, the change gear train is configured with 20 tooth gears in positions A and C, and 80 tooth gears in positions B and D. This is the way the lathe comes from the factory, and is how you should reset it after threading. If you haven't changed the gearing, this is the way your lathe is configured.

To turn with power feed:

1. Put a tool bit in the tool holder and adjust the cutting edge to center height.
2. Angle the tool so that the front cutting edge forms an acute angle with the axis of the workpiece, as shown in the illustration above.
3. Move the carriage so that the tool bit is near the right end of the workpiece.
4. Move the power feed forward/neutral/reverse lever to the forward position.
5. Turn the lathe on. Adjust the speed to an appropriate speed for the material and diameter you are working on. The LittleMachineShop.com Web

site has a calculator to help you determine appropriate cutting speeds at <http://littlemachineshop.com/Reference/CuttingSpeeds.php>.

6. Using the cross slide feed handle, slowly advance the tool bit into the work until it just touches the surface of the workpiece.
7. Move the carriage to the right so that the tool bit is past the end of the workpiece.
8. Using the cross slide feed handle, advance the tool bit about 0.010".
9. Push down on the power feed lever until the half nuts engage. As the tool bit meets the workpiece, it starts cutting.
10. When the carriage has moved as far as you want, raise the power feed lever to disengage the half nuts. The carriage stops.

Chris' Tip: Be sure to move the power feed forward/neutral/reverse lever to the neutral position when you have completed the turning operation.

Facing

Facing is cutting on the end (or face) of the workpiece.

To face a workpiece:

1. Put a tool bit in the tool holder and adjust the cutting edge to center height.
2. Angle the tool so that the side cutting edge forms an acute angle with the face of the workpiece.
3. Move the carriage to the right so that the tool bit is past the right end of the workpiece.
4. Ensure that the power feed forward/neutral/reverse lever is in the neutral position.
5. Push down on the power feed lever until the half nuts engage. You might have to move the carriage slightly so the half nuts will engage.
6. Turn the lathe on. Adjust the speed to an appropriate speed for the material and diameter you are working on. The LittleMachineShop.com Web site has a calculator to help you determine appropriate cutting speeds at <http://littlemachineshop.com/Reference/CuttingSpeeds.php>.
7. Using the compound rest feed handle, slowly advance the tool bit into the work until it just touches the surface of the workpiece.
8. Move the cross slide back so that the tool bit is clear of the diameter of the workpiece.
9. Using the compound rest feed handle, advance the tool bit about 0.005".
10. Using the cross slide feed handle, advance the cross slide slowly. As the tool bit meets the workpiece, it starts cutting.
11. Continue advancing the cross slide until the tool bit reaches the center.

Turning Angles

There are several methods of turning angles or tapers.

- For large angles of short length, such as a chamfer, turn the compound rest to the angle you want. Advance the tool across the work with the compound rest, and advance the tool into the work with the cross slide or the carriage.
- You can use the same method for small angles (usually called tapers) of a length less than the compound rest travel.
- For longer tapers, the work is usually placed between centers with the tail center offset from the centerline of the lathe.



Cutting Threads

Much of the mechanism of your lathe is provided to allow you to cut threads. Your lathe can cut a broad range of thread pitches. In fact, with the standard change gears, you can cut many more thread pitches than those shown on the table on the lathe.

Change Gears

The series of gears that drive the lead screw are called change gears because you change them to turn different thread pitches.

There are 4 positions for the change gears, commonly called A, B, C and D.

A	This is the top change gear position. When you received your lathe it had a 20 tooth metal gear in this position.
B	Gear positions B and C are on the same shaft, between positions A and D. Position B is the inside gear on this shaft. When you received your lathe it had an 80 tooth plastic gear in this position.
C	Gear positions B and C are on the same shaft; between positions A and C. Position C is the outside gear on this shaft. When you received your lathe it had a 20 tooth metal gear in this position.
D	Position D is the end of the lead screw. When you received your lathe it had an 80 tooth plastic gear in this position.

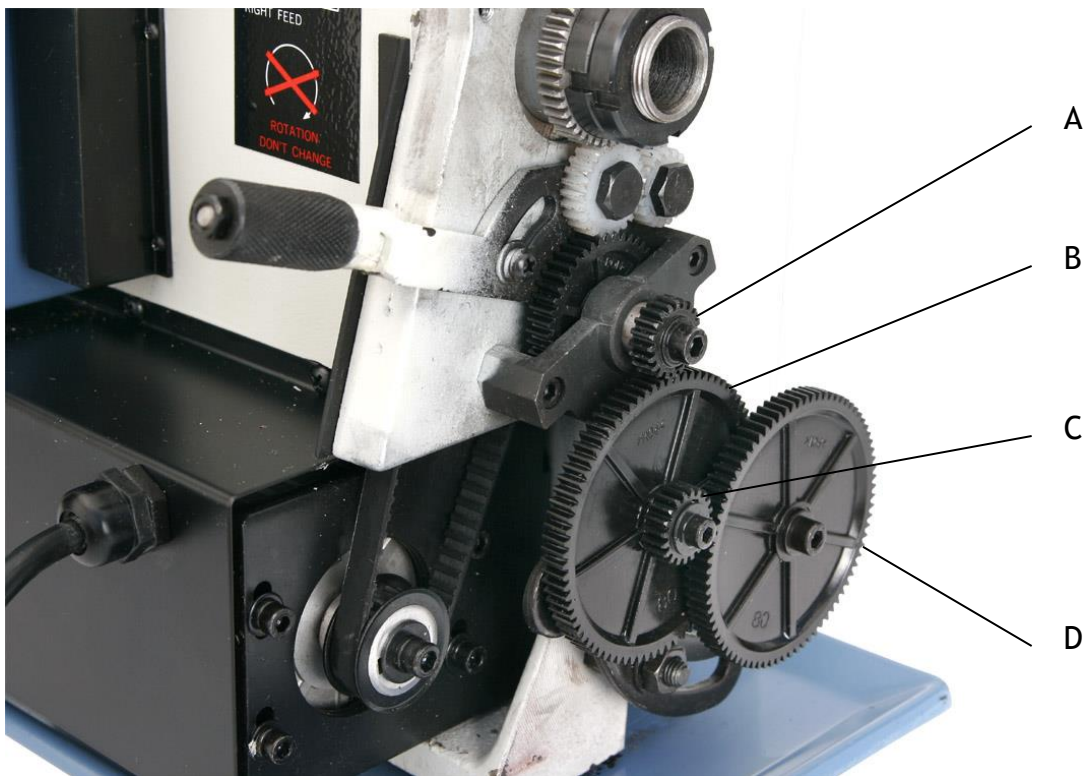

Changing these gears varies the speed that the lead screw turns in relation to the speed that the spindle turns. This allows you to cut threads with different numbers of threads per inch.

The following tables show the gears to use for various common threads.

American Standard Unified Inch Screw Threads

Threads per inch	A	B	C	D
4	80	Any gear		20
4.5	80	40	80	45
5	80	20	40	50
6	80	20	40	60
7	80	Any gear		35
8	40	Any gear		20
9	80	Any gear		45
10	80	Any gear		50
11	80	Any gear		55
11.5	45	35	65	60
12	60	Any gear		45
13	80	Any gear		65
14	40	Any gear		35
16	40	Any gear		40
18	40	Any gear		45
20	40	Any gear		50
24	65	60	40	65
27	40	45	40	60
28	20	Any gear		35
32	20	Any gear		40
36	20	Any gear		45
40	20	Any gear		50
44	20	Any gear		55
48	40	60	40	80
56	40	35	20	80
64	20	Any gear		80
72	40	45	20	80
80	20	80	40	50

American Standard Metric Threads

Pitch (mm)	A	B	C	D
0.3	20	57	35	65
0.35	20	80	50	57
0.4	20	55	45	65
0.45	20	60	55	65
0.5	21	50	45	60
0.6	21	50	45	50
0.7	35	55	45	65
0.75	35	65	50	57
0.8	40	65	45	55
1	21	50	60	40
1.25	35	40	45	50
1.5	40	50	65	55
1.75	40	35	55	57
2	40	50	55	35
2.5	60	55	65	45
3	65	55	80	50
3.5	65	21	57	80
4	55	50	80	35
4.5	55	21	65	60
5	55	35	80	40
5.5	50	55	80	21
6	55	21	65	45
8	57	21	65	35

For normal turning, use the following gears.

A	B	C	D
20	80	20	80

The change gears are commonly tight on the shaft when new. You might need to use a screwdriver behind them to pry them off.

Gear positions B and C are on a hollow shaft that comes off easily when the retaining socket head cap screw is removed. Then you can use an arbor press to remove the gears from the hollow shaft. Be careful that you do not lose the key.

Gear position D has a spacer behind the gear. When you only use three gears, put the spacer on outside the gear so the gear will align with the gear in position B.

In the change gear chart, many of the combinations have “Any” in column B. This means that you can use a gear with any number of teeth in position B. It is an idler and does not affect the overall gear ratio. Use a gear that makes it easy to properly engage the gears. For these combinations, you can use any gear for position C; this gear acts only as a spacer and does not engage the other gears.

To change the gears:

1. Using a 4 mm hex wrench, remove the change gear cover.
2. Using 4 mm and 5 mm hex wrenches, remove all three retaining socket head cap screws from the ends of the shafts.
3. Use a 10 mm end wrench to loosen the nut that is on the back end of the shaft in position B-C. This allows the B-C shaft to move in the adjustment slot.
4. Use a 14 mm end wrench to loosen the nut on the arc below and behind the gear in position D. This allows the entire bracket on which the B-C shaft mounts to swing down.
5. Remove all the gears.
6. If you will be using three gears, remove the spacer behind the D position gear from the end of the lead screw. Be careful that you do not lose the key.
7. Replace the gears with the gears shown in the chart for the threads per inch that you want to cut.
8. If you will be using three gears, replace the spacer outside the D position gear on the end of the lead screw. Be sure to insert the key.
9. If you are using three gears, place any gear in position C to act as a spacer.
10. Replace the three retaining socket head cap screws from the ends of the shafts. Snug, but do not tighten, until the gear train is adjusted.
11. Move the B-C shaft until all the gears are properly engaged.

12. Use a 14 mm end wrench to tighten the nut on the arc below and behind the gear in position D.
13. Use a 10 mm end wrench to tighten the nut that is on the back end of the shaft in position B-C.
14. Using 4 mm and 5 mm hex wrenches, tighten the three retaining socket head cap screws on the ends of the shafts.
15. Using a 4 mm hex wrench, replace the change gear cover.

Threading Dial

When cutting screw threads on a lathe, you must make multiple cutting passes to cut the threads to full depth. The threading dial helps you align the cutting tool with the emerging thread before you start a cutting pass.



The gear on the bottom of the threading dial's shaft engages the lead screw. The dial turns when the half nuts are not engaged with the lead screw. When the half nuts are engaged, the carriage moves and the threading dial stops turning.

The gear on the threading dial has 16 teeth, and the lead screw has 16 threads per inch, so each revolution of the threading dial represents one inch of motion of the carriage. Each of the eight divisions on the dial represents 1/8" of motion.

Chris' Tip: You simply can not use the threading dial when cutting metric threads. Leave the lead screw engaged all the time. When you are done with a pass, note the position of the cross slide dial. Back the cross slide out about two turns. Then run the lathe in reverse until you are back at the starting point.

If you are cutting 16 threads per inch, you can engage the half nuts when the threading dial is on any line. Since a line represents 1/8" of travel, it will always align with a thread groove.

If you are cutting 13 threads per inch, you must only engage the half nuts when the threading dial is at 1. Since 13 and 16 have no common factors but 1, you must only engage the half nuts at even inch increments of motion.

The following table shows where you can engage the half nuts for various threads per inch.

Threads per inch	Dial divisions
12	1, 3, 5, 7
13	1
14	1, 5
16	Any
18	1, 5
19	1
20	1, 3, 5, 7
22	1, 5
24	Any

Threads per inch	Dial divisions
26	1, 5
28	1, 3, 5, 7
32	Any
36	1, 3, 5, 7
38	1, 5
40	Any
44	1, 3, 5, 7
48	Any
52	1, 3, 5, 7

Tool Bit

For threading, the tool bit is ground to the profile of the thread. For most threads, this is a point with a 60° included angle. The front of the tool should have about 10° of relief. No back rake is used. The left side should have about 8° of relief, and the right side should have about 10° of relief. The tip of the tool should have a flat that is 1/8 of the thread pitch.



Compound Angle

Set the compound rest at a 29.5° angle from a line perpendicular to the axis of the lathe. This allows you to advance the tool with the compound rest. At this angle the tool cuts only on the left side of the thread form. This helps prevent chatter that might result from cutting the entire V form of the thread at once.

Chris' Tip: Use an accurate protractor when setting the compound rest. The protractor on the lathe is not accurate enough.

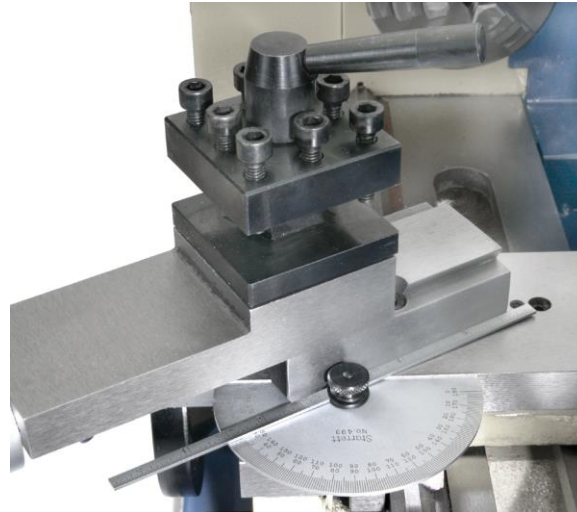

Setting the Cutting Tool

Even though the compound rest is set at an angle to the workpiece, the thread cutting tool must be set square to the workpiece. A center gage makes this setting possible. A center gage has several V-shaped cutouts. They can be used to check the tool bit as you grind it, and to check the angle of the tool with respect to the workpiece.

To align the tool bit to the work:

1. Ensure that the point of the tool bit is set at the center height of the lathe.
2. Place the center gage between the point of the tool bit and the workpiece. Leave enough room so that the center gage can be moved back and forth so you can check each side of the tool bit separately.

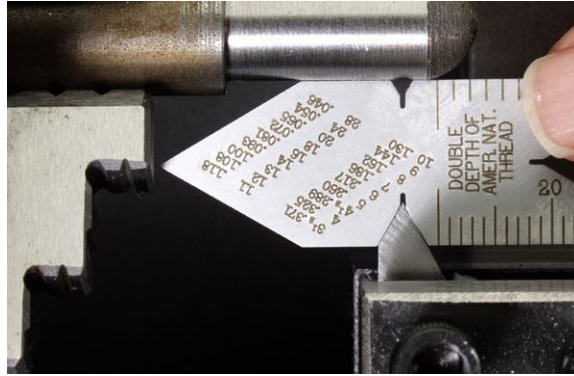

3. Align the tool bit to the sides of the V-shaped cutout in the side of the center gage.
4. Secure the tool bit in position.
5. Advance the tool bit until the point just makes contact with the workpiece.
6. Zero the cross slide dial. Hold the cross slide feed handle and rotate the graduated dial.

Threading Process

It takes several passes to cut a thread to full depth. You must follow the correct procedure during each pass to ensure the thread is cut correctly.

Use the power feed forward/neutral/reverse lever to engage the lead screw drive. The carriage should move from right to left (toward the head stock) to cut right-hand threads, or from left to right (away from the head stock) to cut left-hand threads.

For each pass in cutting threads:

1. Move the carriage to the beginning of the cut.
2. Advance the cross slide to the initial position. For the first pass, you are already there. For additional passes, advance it 2 complete turns to the 0 mark.
3. Advance the compound rest to move the tool bit into the work. For the first pass, this should be only 0.001". For additional passes, it should be 0.005 to 0.010".
4. Start the lathe. Run it at the lowest speed that develops sufficient torque to make the cut.
5. When the threading dial reaches an appropriate mark, engage the half nuts. Note that you must be right on the mark. The half nuts will also engage half way between each mark, but this will ruin your thread.
6. When the tool reaches the end of the thread, disengage the half nuts.
7. Back off the cross slide exactly 2 turns.

After you have made the first pass, which should leave just a spiral mark on the workpiece, use a thread gage to check that you are cutting the correct number of threads per inch.

Use a nut or the matching part to tell when you are done cutting the thread.

Common Accessories

You will soon find that the purchase of a lathe is just an initial step. There are many tools and accessories that you will need to get full use from your lathe. LittleMachineShop.com carries a full selection of accessories. Following are some common accessories used with the mini lathe, a small sampling of the complete LittleMachineShop.com line.

Cut-Off Tool Holder

Cutting-off, or parting, is a common procedure on a lathe. Once you have turned a piece on the end of a rod, you use a cut-off tool to part the work from the rod. Cut-off tools come in various widths, from about 0.040" wide, to much wider than can be used with a mini lathe. Most cut-off blades are ½" tall, which means they will not fit in the tool post that comes with the mini lathe.

The cut-off tool holder shown below fits in the standard tool post and holds a ½" tall cut-off blade.



LittleMachineShop.com part number 1551.

This cut-off tool holder fits in the standard 4-way tool post (and most other tool posts) and holds 1/2" tall cut-off blades.

Quick Change Tool Post

The standard mini lathe tool post has positions for up to four tools. While this is useful, the standard mini lathe tool post does not have the capability to hold boring bars or cut-off tools without an adapter of some sort.

Quick-change tool posts provide several advantages. They provide an easy way to adjust the height of the tool bit. They provide a quick way to change from one tool to the other. They provide a way to hold several different kinds of tools, usually including turning tools, cut-off blades, and boring bars. And they are indexable, meaning that you can remove a tool, and when you replace it, it returns to the same position, with no adjustment necessary.



LittleMachineShop.com part number [3112](http://LittleMachineShop.com). This is a very high quality quick-change tool post for the HiTorque Mini Lathe.

It holds tools up to 3/8" shank.

The set includes:

- Tool post
- Turning & facing tool holder
- Boring, turning & facing tool holder
- Heavy duty boring tool holder
- Universal parting blade holder
- Knurling, facing & turning tool holder

Chris' Tip: This quick change tool post set is included with the Model 5200 deluxe mini lathe.

Indexable Turning Tools

Indexable turning tools usually come in a set of five tools, providing a range of cutting angles. These tools use indexable inserts, usually made from carbide, but sometimes from high-speed steel. They are called indexable because you can change an insert and the new insert will take the exact position of the insert it replaces. You can resume work with no further adjustments. Indexable inserts are pre-sharpened.



LittleMachineShop.com part number [1669](http://LittleMachineShop.com). This set of indexable turning tools includes 5 tools (AR, AL, BR, BL, TE), wrenches, and extra screws. It comes in a fitted case. (The letters designate the angles of the cutting edge.)

4-Jaw Chuck

The 3-jaw scroll chuck that comes with the mini lathe provides a quick way to clamp round and hexagonal work fairly accurately.

A 4-jaw independent chuck provides several advantages over a 3-jaw scroll chuck. It can hold square or rectangular work, as well as round. Work can be centered more accurately because you adjust each jaw independently. It can hold larger work than the same size 3-jaw chuck. You can offset work in a 4-jaw chuck by clamping it off center.



LittleMachineShop.com part number 1697. 4 inch, 4-Jaw chuck. Each jaw is independently adjustable and reversible.

This set includes a chuck key and reversible jaws plus an adapter to mount the 4" lathe chuck on the HiTorque Mini Lathe. The through bore of this chuck is 0.98". The chuck can hold work up to 100 mm (3.94") in diameter.

Faceplate

A faceplate allows you to mount work that can't be held in a chuck. You can bolt odd-shaped workpieces to the faceplate.



LittleMachineShop.com part number 5123. Faceplate for the HiTorque Mini Lathe. The faceplate is 6.29" (160 mm) in diameter and has 8 slots for mounting work.

LittleMachineShop.com part number 2644. Clamping kit for faceplate. This kit includes clamping bars and fasteners to attach work to the faceplate.

Centers and Dogs

A live center goes in the tailstock and is used to support the end of a long workpiece; it rotates with the workpiece. A dead center goes in the spindle and supports work being turned between two centers. A lathe dog is used to drive work being turned between centers.



The live center is LittleMachineShop.com part number 1189. It has a 2 Morse taper shank. This center fits the tailstock of the mini lathe.

The dead center is LittleMachineShop.com part number 1188. It has a 3 Morse taper shank. This center fits the headstock of the mini lathe. The center has a 60 degree included point angle.

The lathe dog set is LittleMachineShop.com part number 4464. This lathe dog set can handle work up to 1.5" (40 mm).

Steady Rest and Follower Rest

Steady and follower rests support small diameter work that would otherwise flex too much. A steady rest mounts in a fixed position on the ways of the lathe. A follower rest mounts on the carriage and moves with the cutting tool, providing support where it is needed.

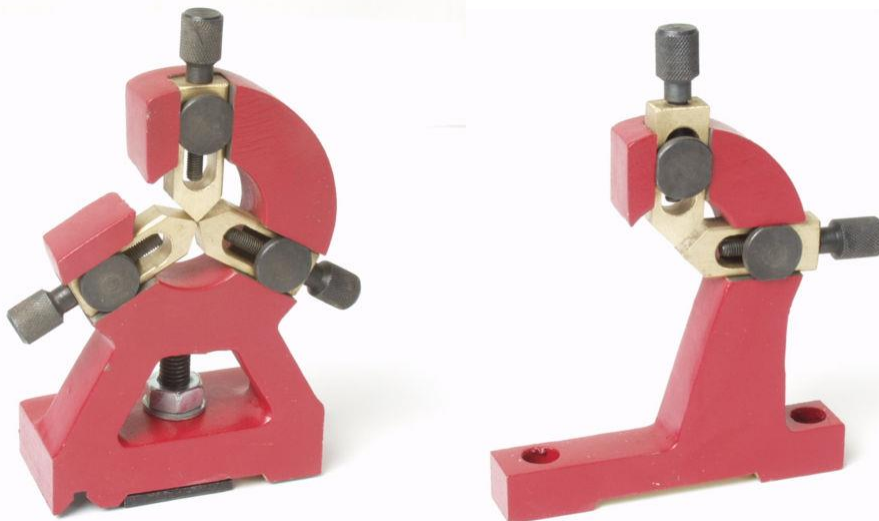

The steady rest is LittleMachineShop.com part number 1197. The steady rest can support work up to 1.5" in diameter.

The follower rest is LittleMachineShop.com part number 1198.

Parts Diagram

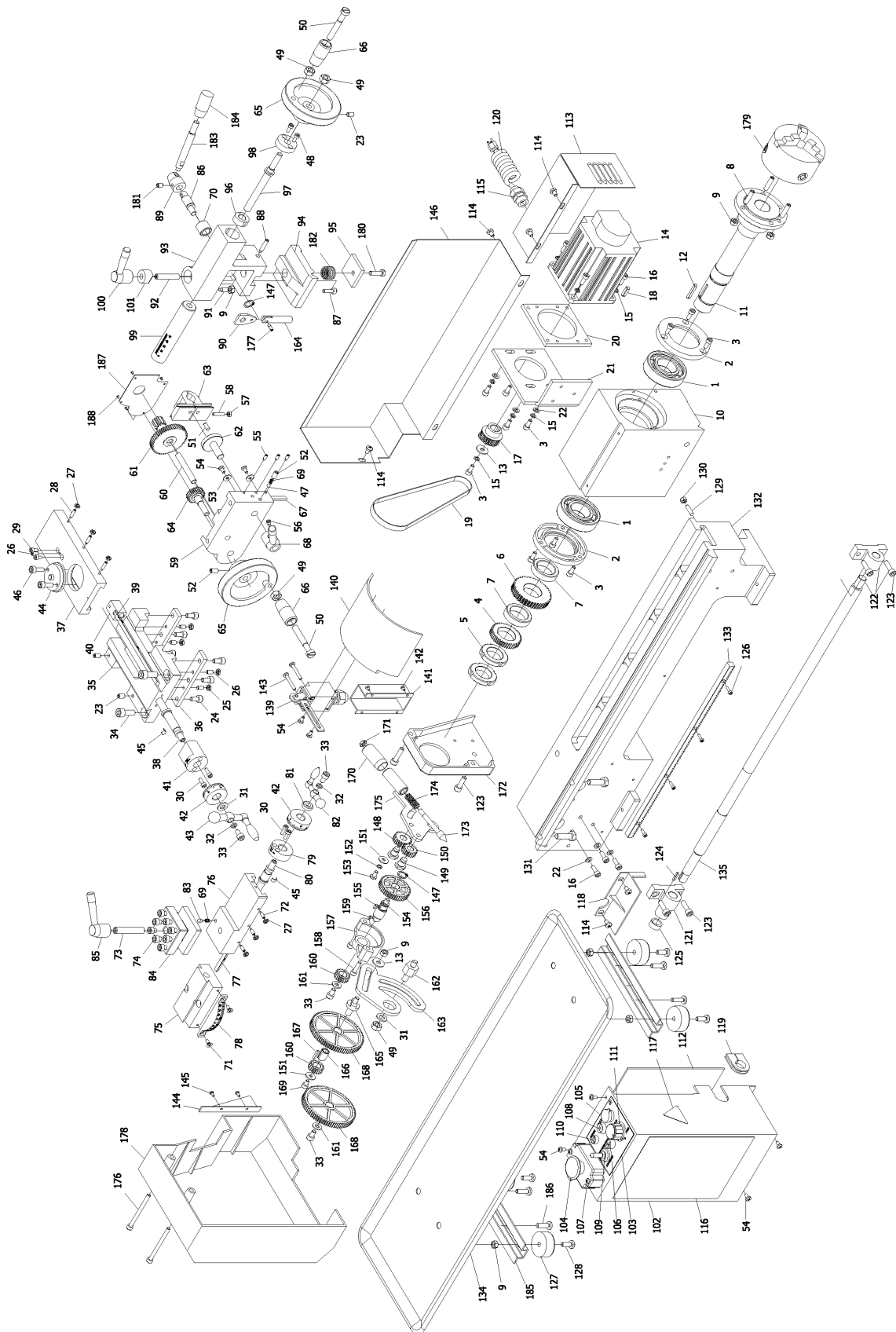

Parts List

Item	Description	Qty.
1	Bearing 80206	2
2	Cover	2
3	Screw M5x12	11
4	Spindle gear	1
5	Nut M27x1.5	2
6	Pulley	1
7	Spacer	2
8	Screw M6x25	3
9	Nut M6	9
10	Headstock Casting	1
11	Spindle	1
12	Parallel Key 4x28	1
13	Washer 6	2
14	Brushless motor 500W	1
15	Spring Washer 5	9
16	Screw M5x14	7
17	Pulley	1
18	Parallel Key 5x18	1
19	Timing belt	1
20	Motor connector	1
21	Bracket for motor	1
22	Washer 5	7
23	Screw M6x10	3
24	Screw M6x12	6
25	Nut M5	4
26	Screw M5x10	5
27	Nut M4	6
28	Screw M4x16	3
29	Screw M4x8	2
30	Screw M4x12	4
31	Washer 8	2
32	Spring washer M6	2

Item	Description	Qty.
33	Screw M6x10	4
34	Screw M6x20	2
35	Saddle	1
36	Press board	2
37	Cross Slide	1
38	Feeding screw (metric)	1
39	Gib strip	1
40	Feeding nut	1
41	Fixing ring (imperial/metric)	1
42	Dial (imperial)	2
43	Handle (big)	1
44	Orientation	1
45	Spring patch	2
46	Screw M6x16	2
47	Steel ball	1
48	Screw M4x10	2
49	Nut M8	4
50	Screw M8x55	2
51	Round Pin A5x12	2
52	Screw M6x12	2
53	Washer 4	2
54	Screw (H type)	8
55	Screw M4x10	3
56	Screw M6x8	1
57	Nut M4	1
58	Screw M4x20	1
59	Apron	1
60	Shaft	1
61	H/L Gear	1
62	Groove Cam	1
63	Half nut (metric)	1

Item	Description	Qty.
64	Feeding Gear	1
65	Hand wheel	2
66	Handle	2
67	Gib strip	1
68	Handle assembly	1
69	Spring	2
70	Sleeve	1
71	Screw M4x10	2
72	Screw M4x12	3
73	Screw M10x50	1
74	Screw M6x25	9
75	Compound rest	1
76	Slider	1
77	Gib strip	1
78	Angle block	1
79	Bracket	1
80	Cross feeding screw	1
81	Washer	1
82	Handle	1
83	Positioning pin	1
84	Tool rest	1
85	Handle set	1
86	Cam brake shaft	1
87	Screw M5x16	1
88	Screw M5x25	1
89	Brake shaft	1
90	Connecting plate	1
91	Screw M6x14	1
92	Screw M8x40	1
93	Tailstock casting	1
94	Bottom board	1
95	Plate of tailstock	1
96	Washer	1
97	Tailstock screw	1

Item	Description	Qty.
98	Flange	1
99	Tailstock	1
100	Handle base	1
101	Clamp	1
102	Cover	1
103	Switch label	1
104	Magnetic switch	1
105	Connector	1
106	Fuse	1
107	Screw M4x10	2
108	Yellow indicator light	1
109	Switch	1
110	Power indicator	1
111	Knob	1
112	PC board	1
113	Motor cover	1
114	Screw M5x8	7
115	Rubber gasket	1
116	Specification label	1
117	Lightning label	1
118	Defend board	1
119	Dustproof cover	1
120	Power cord	1
121	Left bracket	1
122	Right bracket	1
123	Screw M6x20	5
124	Parallel key 3x16	1
125	Washer	1
126	Screw M3x10	4
127	Rubber pad	4
128	Screw M6x16	4
129	Screw M5x20	1
130	Nut M5	1
131	Screw M8x25	3

Item	Description	Qty.
132	Bed way	1
133	Long rack	1
134	Oil ray	1
135	Lead screw (metric)	1
136	Lead screw cover	1
137	Washer	3
138	Screw (H type)	3
139	Limit switch	1
140	Chuck cover	1
141	Switch box	1
142	Screw (H type)	4
143	Screw (H type)	2
144	Fixing plate	1
145	Screw (H type)	2
146	Fence	1
147	Circlip	2
148	Gear I	1
149	Gear shaft	2
150	Gear II	1
151	Washer	2
152	Spring washer	1
153	Screw (H type)	1
154	Gear retainer	1
155	Key	1
156	Gear	1
157	Gear rack	1
158	Bolt	2
159	Key	1
160	Changing gear	2
161	Washer	2
162	Fixing bolt	1
163	Gear support	1
164	Slotted fixing shaft	1
165	Bolt shaft	1

Item	Description	Qty.
166	Gasket	1
167	Key	1
168	Changing gear	2
169	Screw	1
170	Handle sleeve	1
171	Hex nut	1
172	Gear fixing plate	1
173	Fixing pin	1
174	Compressing spring	1
175	Sector plate	1
176	Screw	2
177	Setscrew	1
178	Cover	1
179	Chuck	1
180	Screw	1
181	Tap screw	1
182	Compressing spring	1
183	Shank	1
184	Handle sleeve	1
185		2
186	Screw (H type)	4
187	Apron cover	1
188	Label rivet	4

DRO Parts

P/N	Description
2373	Readout, DRO
2371	Retainer, DRO Cross Slide Screw
2368	Screw, DRO Cross Slide
2372	Retainer, DRO Compound Rest Screw
2369	Screw, DRO Compound Rest
2300	Set Screw, M2x4 Slot Cone Point
2370	DRO Accessory Pack

Wiring Diagram

